

Welcome

The Rosenberg Group



Presentation Overview

i. Who are we ?

- Relevant data
- Rosenberg Ventilatoren GmbH
 - Headquarters
 - Glaubitz Production AHU
- Rosenberg worldwide

ii. What we stand for ?

- Philosophy

iii. Where do we come from ?

- History

iv. What do we do ?

- Product range Standard
- Product range OEM fans
- Product range Air handling units (AHU)

v. What we offer you ...

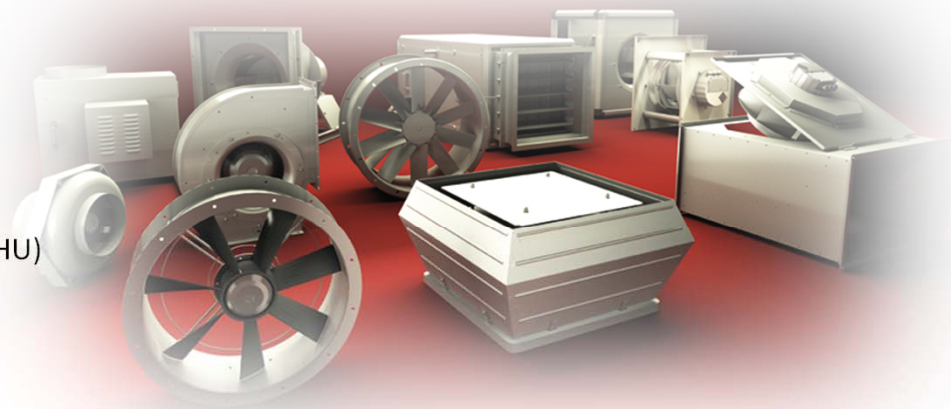
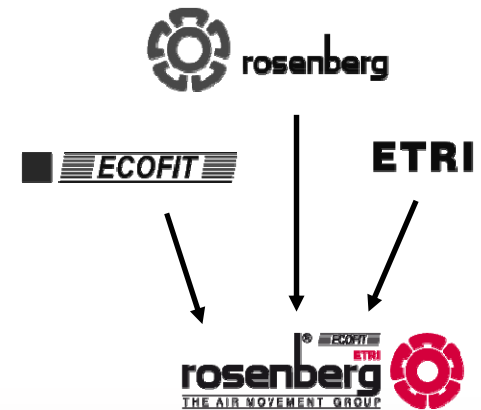

Presentation Overview

i. Who are we ?

- Relevant data
- Rosenberg Ventilatoren GmbH
 - Headquarters
 - Glaubitz Production AHU
- Rosenberg worldwide

ii. What we stand for ?

- Philosophy

iii. Where do we come from ?

- History

iv. What do we do ?

- Product range Standard
- Product range OEM fans
- Product range Air handling units (AHU)

v. What we offer you ...

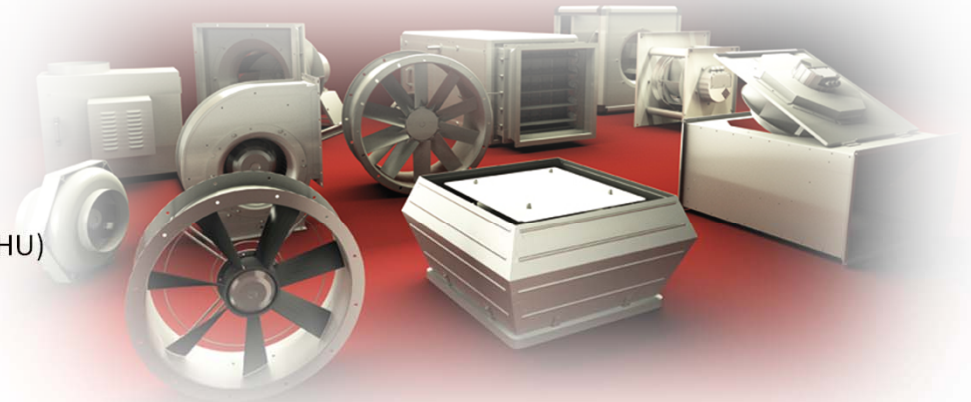
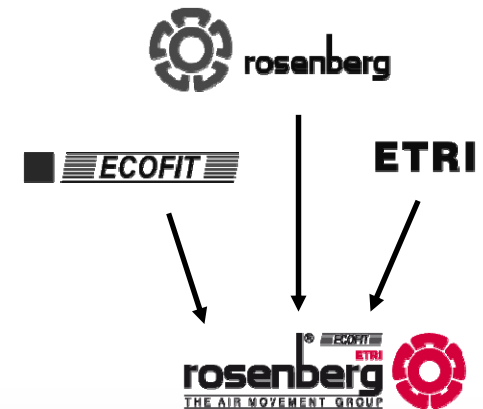

i. Who are we ? - Relevant data



Foundation:	1981
Sales offices:	45
Export share in %:	60
<u>Employees</u>	
Germany:	310
Worldwide:	1.400

Production locations:

Künzelsau (GER), Glaubitz (GER), Waldmünchen (GER), Hungary, Czech Republic, Italy, France, Slovakia, China

R&D-Centers:

Germany, France , Hungary, China

Products:

controllable external rotor motors, fans, Plug & Play Units , AHU's, controls

i. Who are we ? - Relevant data

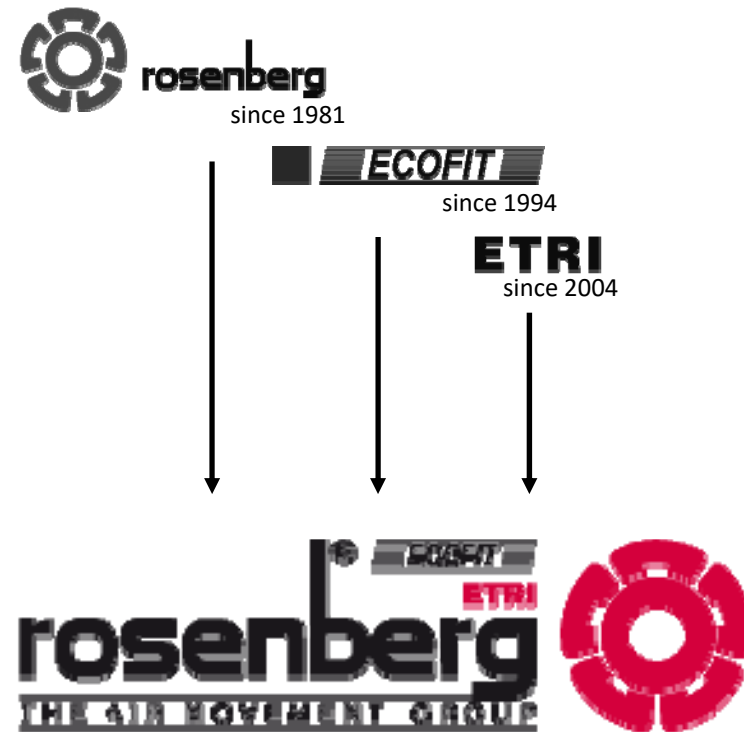

i. Who are we ? - Rosenberg Ventilatoren GmbH - Headquarters



i. **Who are we ?** - Headquarters - Extension building - 08/2011



i. **Who are we ?** - Headquarters - Extension building - 03/2012



i. Who are we ? - Headquarters - Research & Development

- 3 airflow testing chambers (Large, Medium, Small)
- Low reflection noise test chamber
- Motor torque test stand
- Centrifuging chamber (impeller testing)



Performance curve testing



Noise test chamber

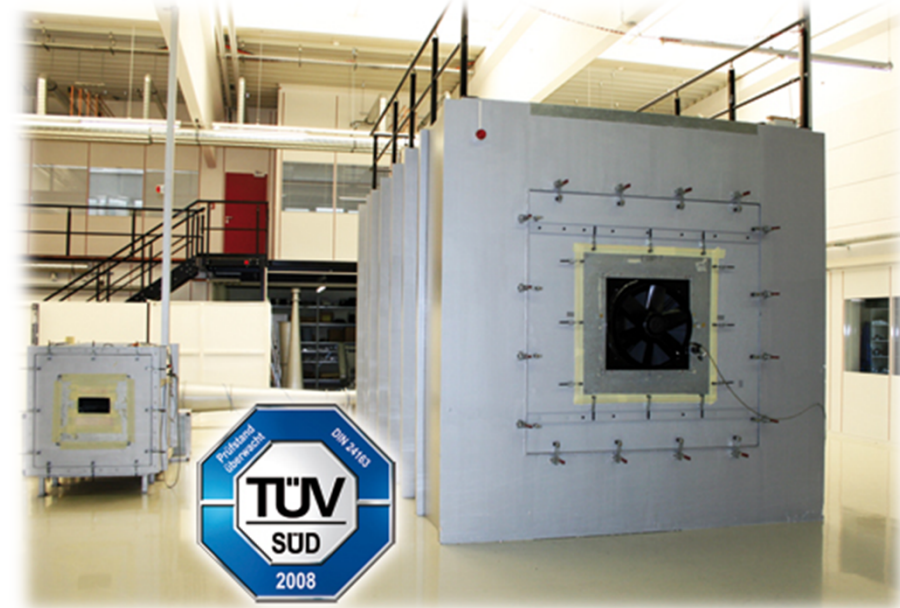

Airflow testing chambers

i. Who are we ? - Headquarters - Research & Development



i. **Who are we ?** - Headquarters - Research & Development



i. Who are we ? - Headquarters - Research & Development



i. Who are we ? - Headquarters - Research & Development

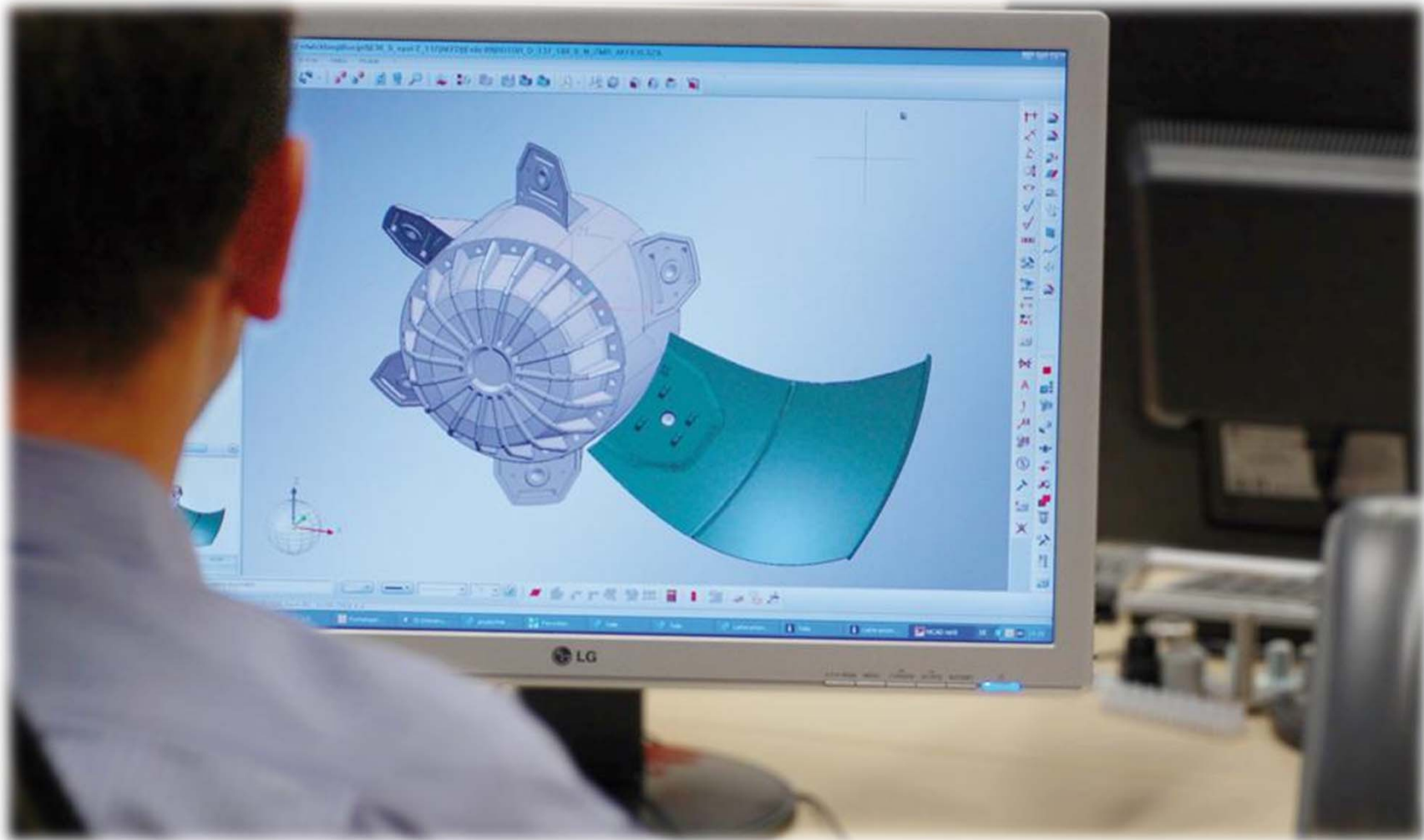

i. Who are we ? - Headquarters - Motor production

- Current facility size: 3000 m²
- Production of own external rotor AC-motors since 1990
- Production of own EC-Motors since 2006
- Modern production with automatic winding machines
- Stators and rotors from welding and casting facility (SK)
- Machines are built in our own tool shop



i. **Who are we ?** - Headquarters - Motor production



i. **Who are we ?** - Headquarters - Motor production

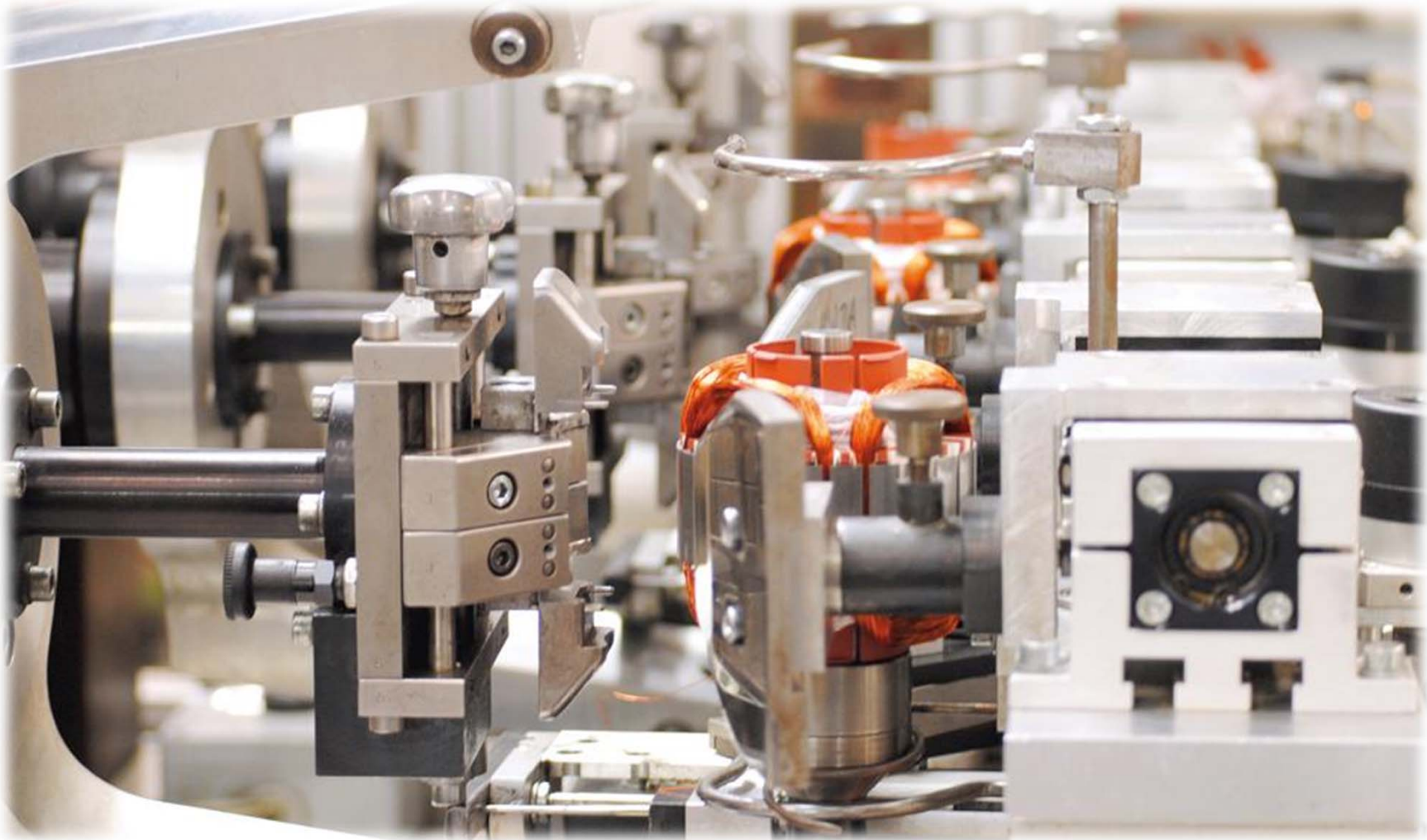

i. **Who are we ?** - Headquarters - Motor production



i. Who are we ? - Headquarters - Motor production

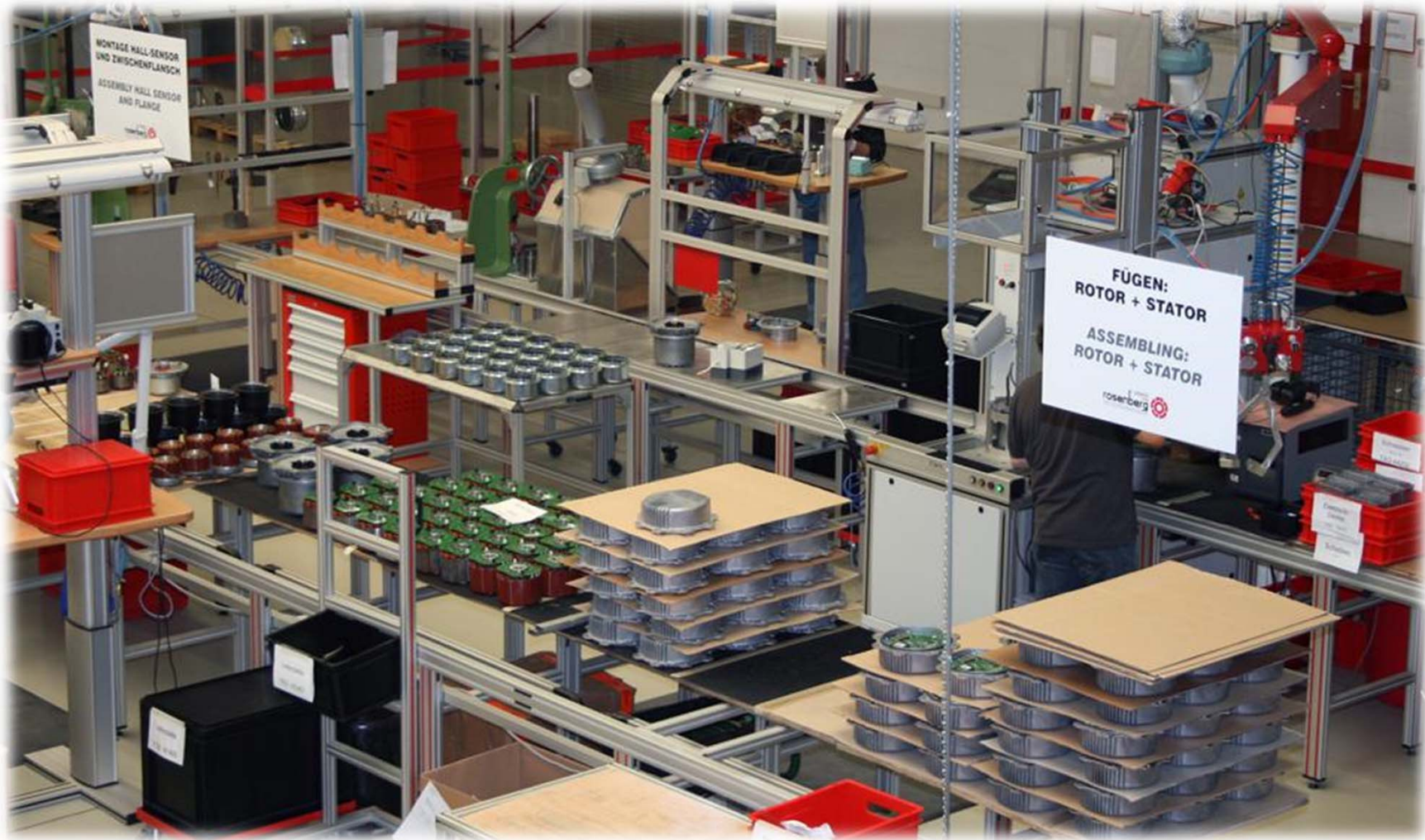

i. Who are we ? - Headquarters - Fan assembling

- Current facility size: 1000 m²
- All main components from our own production (GER, IT, CZ)
 - ❖ Casings
 - ❖ Impellers
 - ❖ Motors



i. **Who are we ?** - Headquarters - Fan assembling



i. **Who are we ?** - Headquarters - Fan assembling



i. **Who are we ?** - Headquarters - Fan assembling



i. **Who are we ?** - Headquarters - Fan assembling



i. Who are we ? - Glaubitz - AHU production

- Foundation: 2001
- Current facility size: 11.000 m²
- Employees: 85
- Product range:
 - ❖ AHU's
 - ❖ ERU's
 - ❖ ERU's specially designed for classrooms



i. **Who are we ?** - Glaubitz - AHU production



i. Who are we ? - Glaubitz - AHU production



i. **Who are we ?** - Glaubitz - AHU production

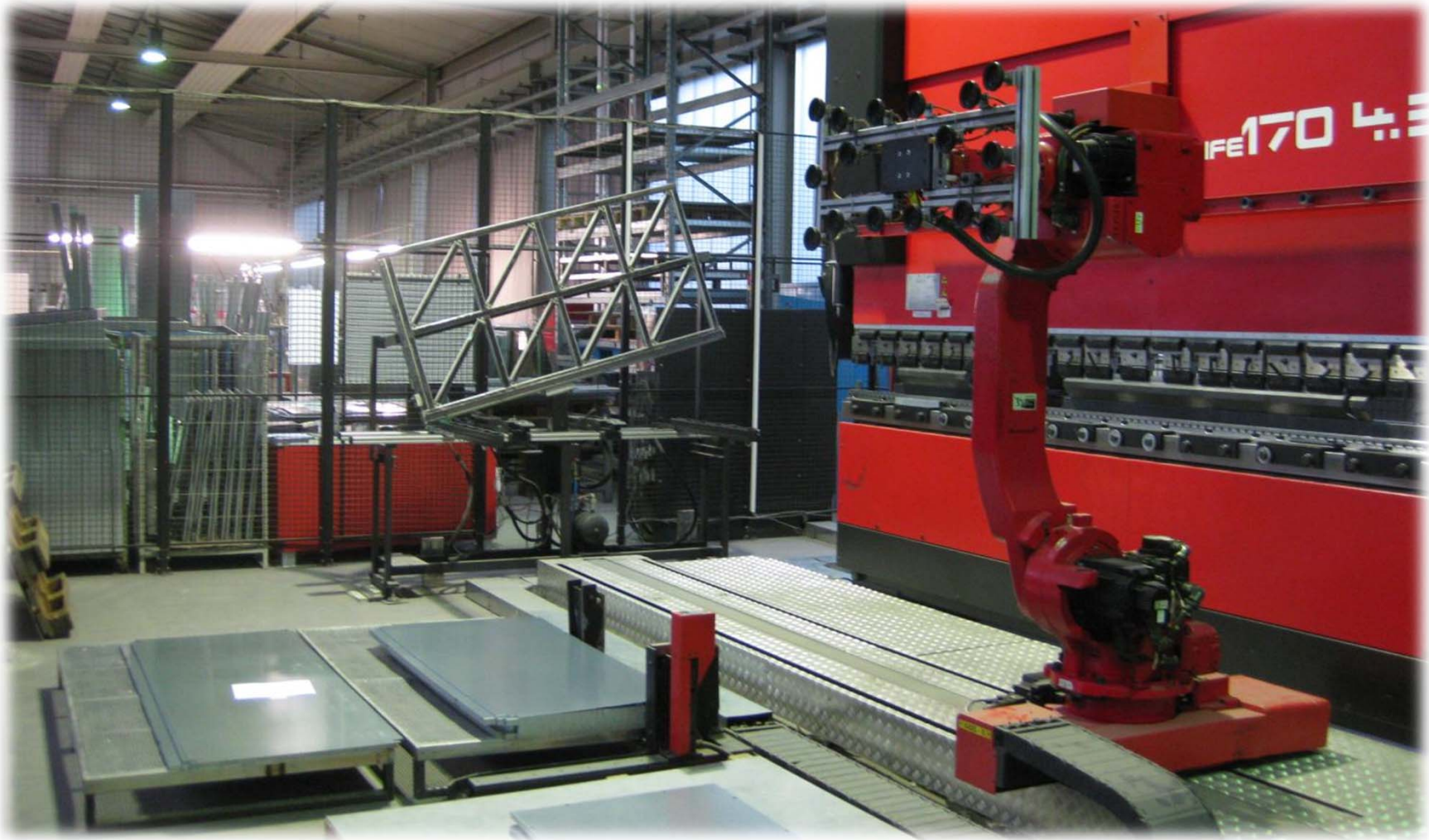

i. **Who are we ?** - Glaubitz - AHU production



i. **Who are we ?** - Glaubitz - AHU production

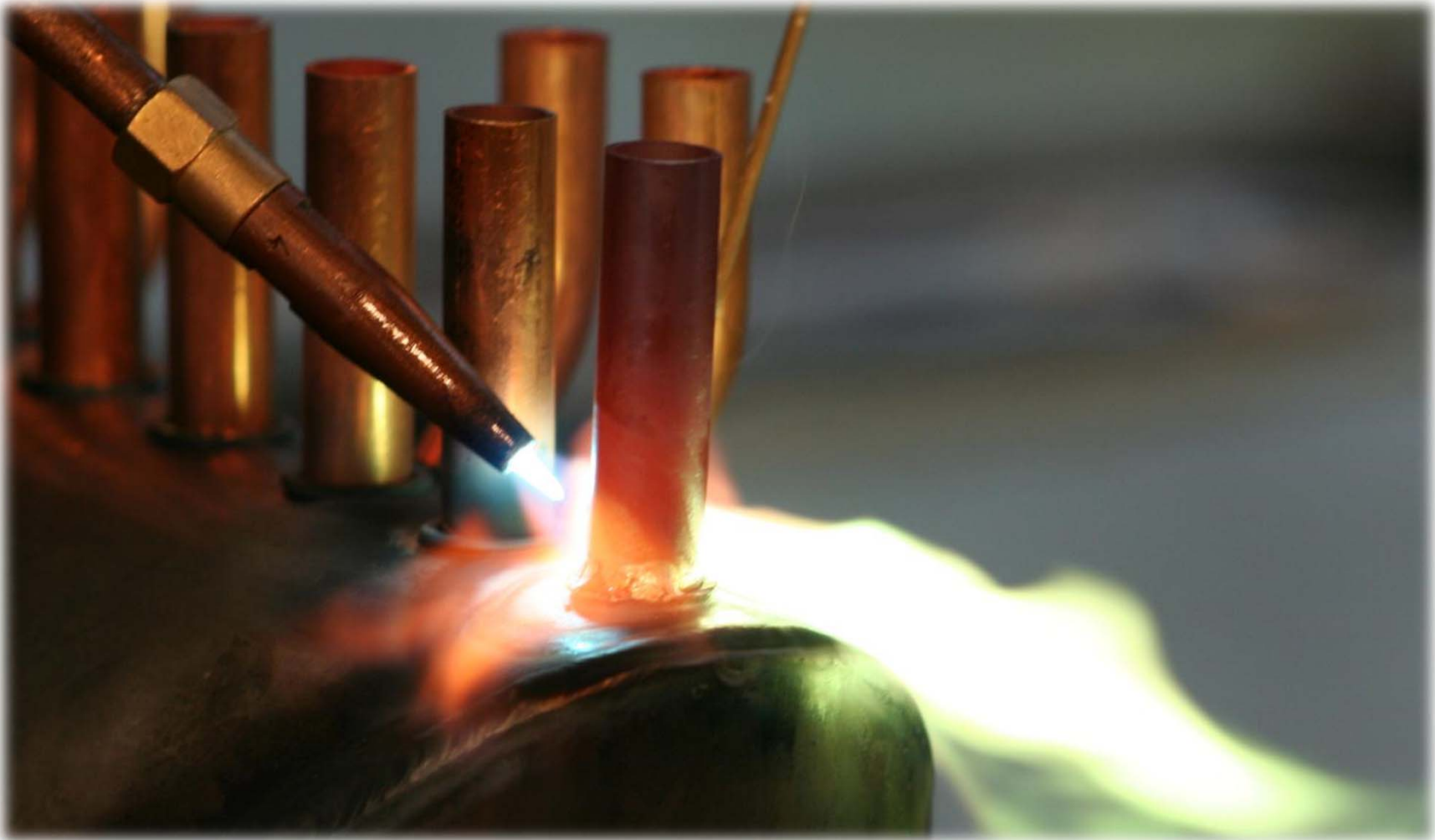

i. **Who are we ?** - Glaubitz - AHU production



i. Who are we ? - Rosenberg worldwide

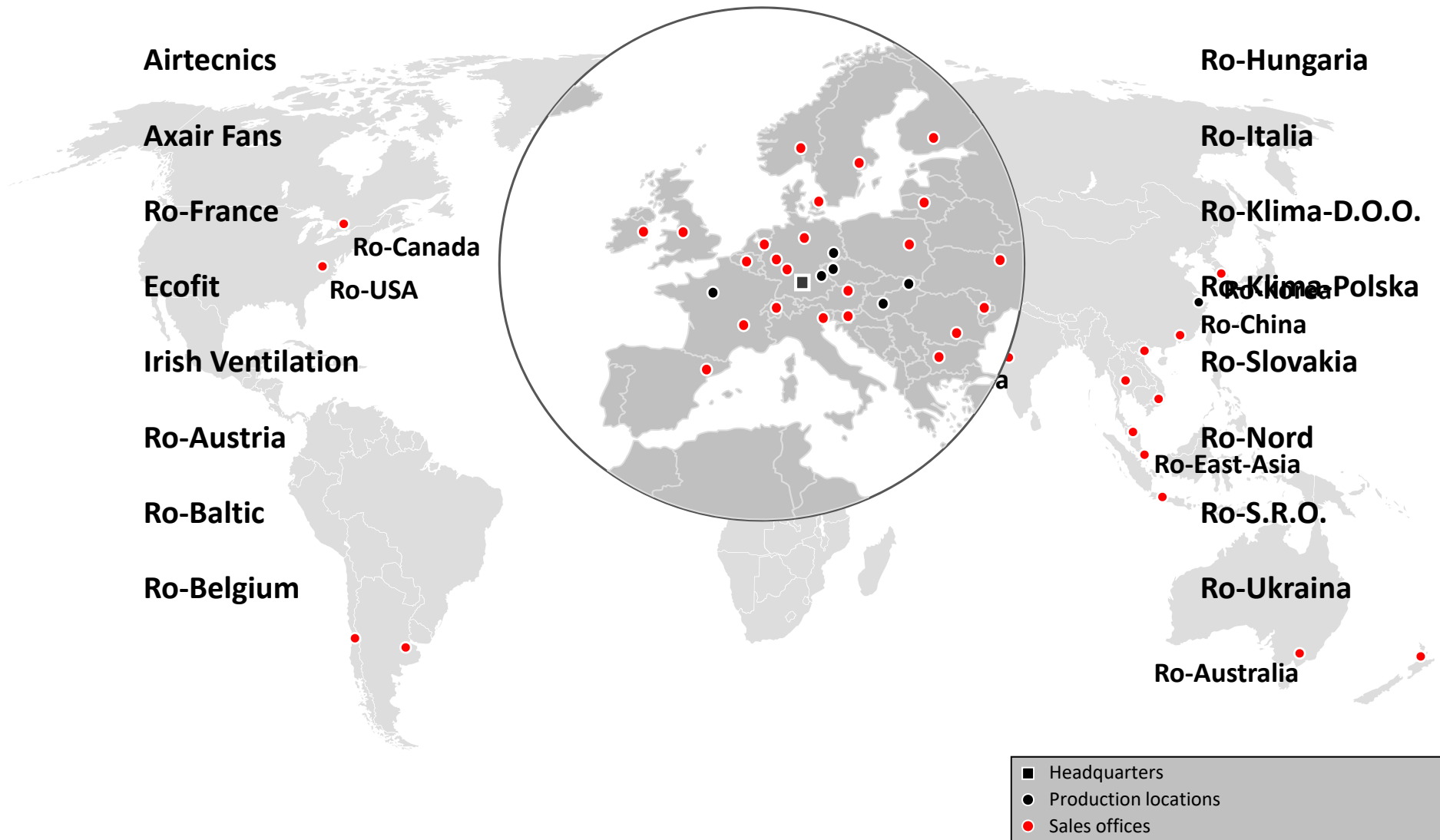

Presentation Overview

i. Who are we ?

- Relevant data
- Rosenberg Ventilatoren GmbH
 - Headquarters
 - Glaubitz Production AHU
- Rosenberg worldwide

ii. What we stand for ?

- Philosophy

iii. Where do we come from ?

- History

iv. What do we do ?

- Product range Standard
- Product range OEM fans
- Product range Air handling units (AHU)

v. What we offer you ...

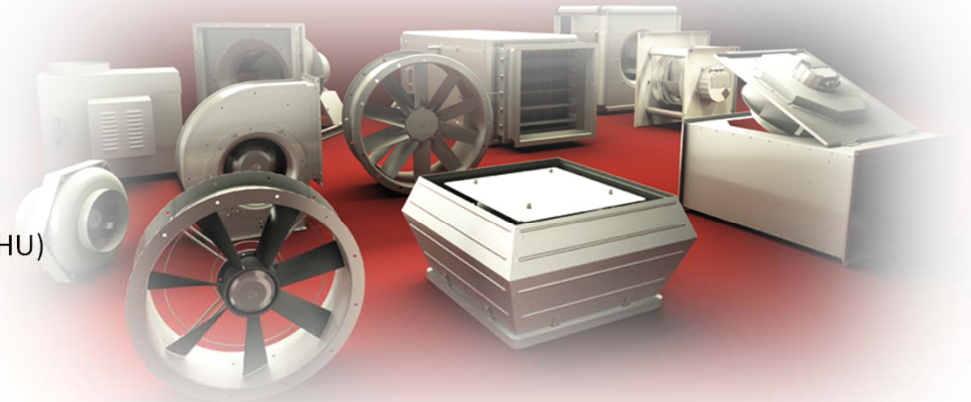
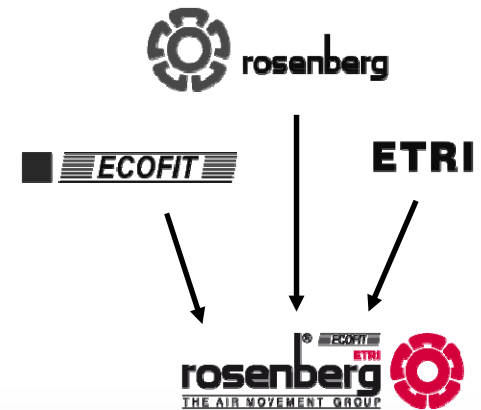

ii. What we stand for ? - Philosophy

Air is our element ...

... we offer intelligent solutions to move air efficiently – no matter whether it is hot or cold



Our success factors ...

... Production steps - Know-How – Close customer relationships

ii. What we stand for ? - Philosophy

Primary Objective

Energy saving and high quality products

Continuous improvement of products and quality by:

- State of the art test-lab
- Computer controlled machines
- Self empowered work groups
- Integration of environmental protection activities
- Certified according DIN EN ISO 9001
- Member of the “RLT-Herstellerverband”
(Association of manufacturers for HVAC appliances)

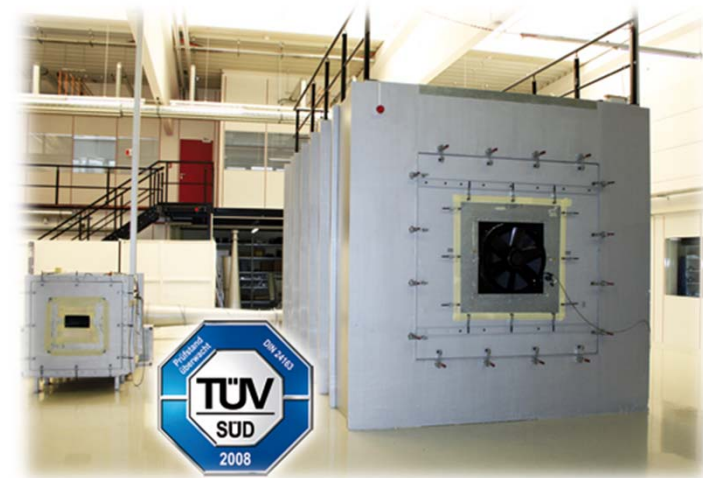

Our precision is measurable ...

... we stand for uncompromising quality

Presentation Overview

i. Who are we ?

- Relevant data
- Rosenberg Ventilatoren GmbH
 - Headquarters
 - Glaubitz Production AHU
- Rosenberg worldwide

ii. What we stand for ?

- Philosophy

iii. Where do we come from ?

- History

iv. What do we do ?

- Product range Standard
- Product range OEM fans
- Product range Air handling units (AHU)

v. What we offer you ...

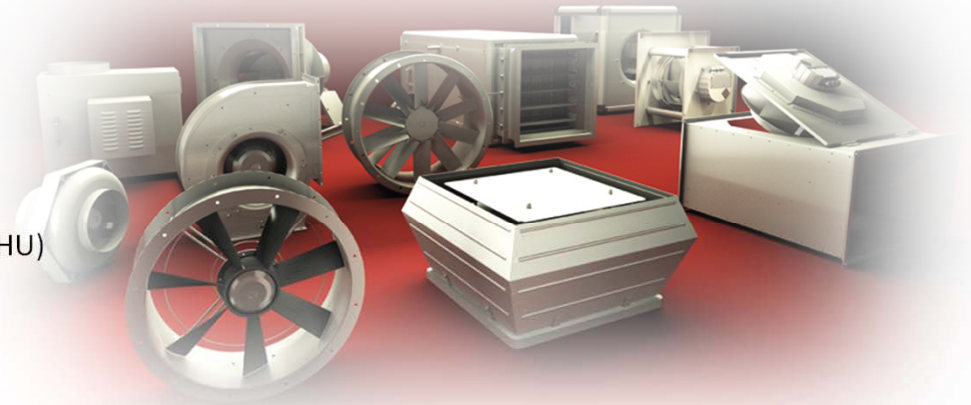
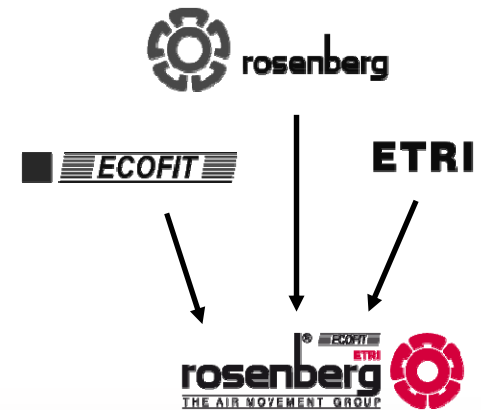

iii. Where do we come from ? - History

THE FIRST YEARS

- 1981 Foundation of the **Rosenberg Ventilatoren GmbH** in Künzelsau
- 1983 Establishment of the first foreign branches:
 - **Rosenberg - France (Airpro)** in Lyon
 - **Rosenberg - Netherlands** in Den Dolder
- 1986 Foundation of **Airtecnicos** in Barcelona (Spain)

NEW CHALLENGES

- 1987 **Air Handling Unit (AHU) production** starts in Künzelsau
- 1990 Production of **external rotor motors** starts in Künzelsau
- 1991 Production of **belt driven centrifugal fans** starts in Waldmünchen (Bavairia)
- 1992 **Rosenberg - Italia (San Vito)** begins to produce forward curved impellers

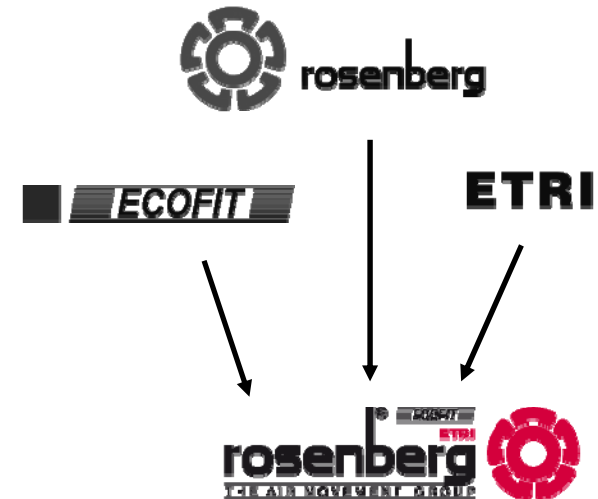

iii. Where do we come from ? - History

GROWTH IN EUROPE

- 1993** Production of motor components starts in **Klenci** (Czech Republic)
- 1994** Takeover of the French fan manufacturer **ECOFIT** (Vendôme)
- 1995** Production of AHU's starts in **Tokodaltaro** (Hungary)
- 1998** Opening of **Russian sales offices** in Moscow, St. Petersburg and Novosibirsk
- 1998** Enlargement of AHU production in Hungary to 10.000 m² especially for the Eastern European market
- 2001** Start of a new production line for AHU's in **Glaubitz** (near Riesa)
- 2002** Takeover of the French fan manufacturer **ETRI** by our subsidiary ECOFIT
Own branch office in Charlotte (USA): Etri Inc.
=> **Rosenberg - USA**

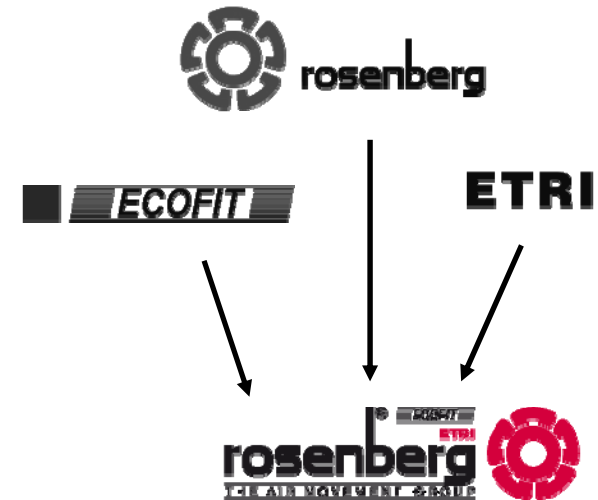

iii. Where do we come from ? - History

GLOBALIZATION

- 2003** Foundation of 100% subsidiaries
 - **Melbourne** (Australia)
 - **Shanghai** (China)

- 2004** Sales offices in Dubai and Kiev
 - **Rosenberg Middle East** for the Arab market
 - **Rosenberg Ukraina**

- 2005** Development and production of EC-Motors

- 2006** Expansion of the segment „Air conditioning technology“ by taking over the ROX Lufttechnik GmbH (Weitefeld)
 Relaunch of the **ROX Klimatechnik GmbH**

- 2008** **Certification** of the test chambers in Künzelsau by TÜV-SÜD

- 2010** Opening of the new casting and stamping in **Medzev** (Slovakia)

- 2011** Dedication of the **new production hall** (4.400 m²) in Künzelsau

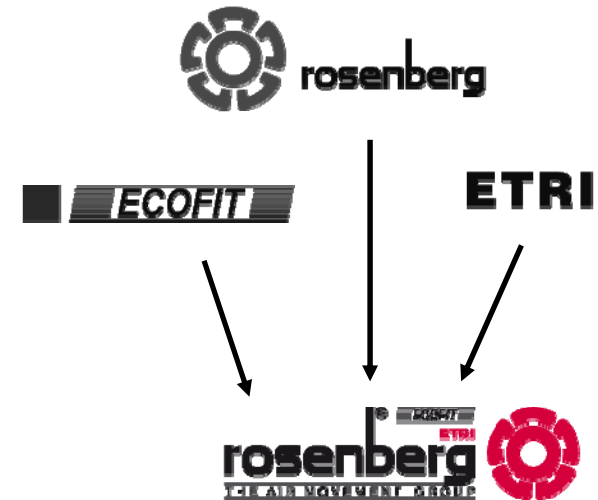

Presentation Overview

i. Who are we ?

- Relevant data
- Rosenberg Ventilatoren GmbH
 - Headquarters
 - Glaubitz Production AHU
- Rosenberg worldwide

ii. What we stand for ?

- Philosophy

iii. Where do we come from ?

- History

iv. What do we do ?

- Product range Standard
- Product range OEM fans
- Product range Air handling units (AHU)

v. What we offer you ...

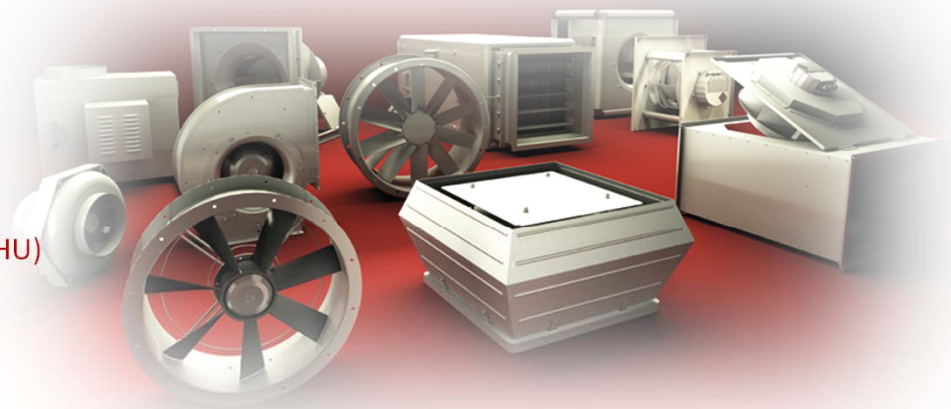
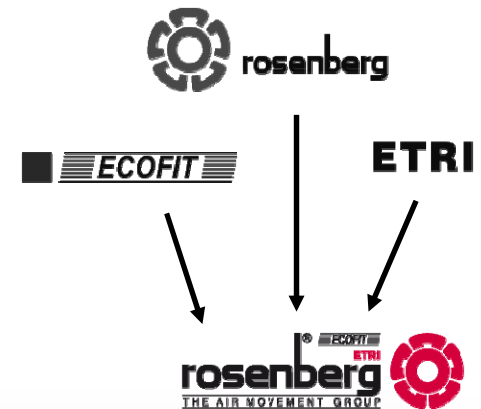

iv. What do we do ? - Product range standard

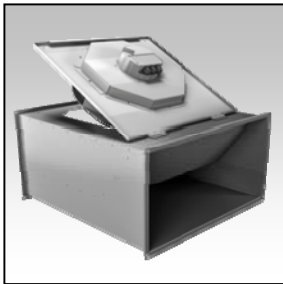

Duct fans

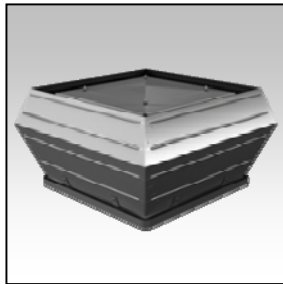

Roof fans

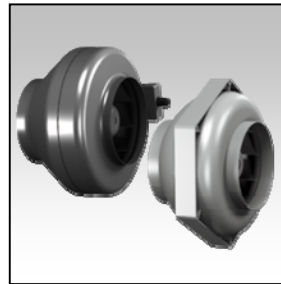

Tube fans

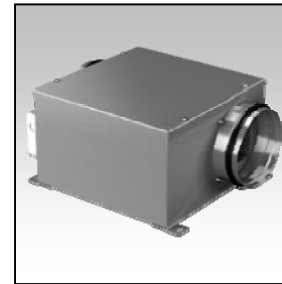

Zerox

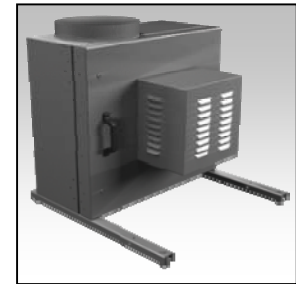

Kitchen exhaust box

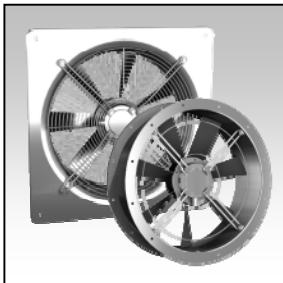

Axial fans

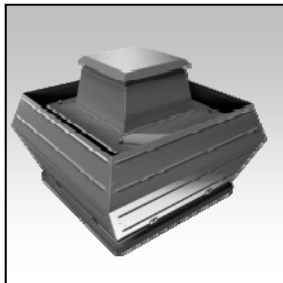

Roof fans with IEC standard motor

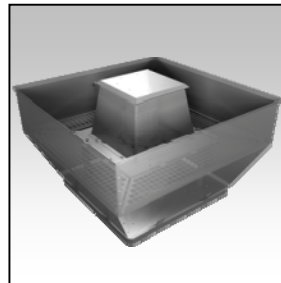

Smoke extract roof fans

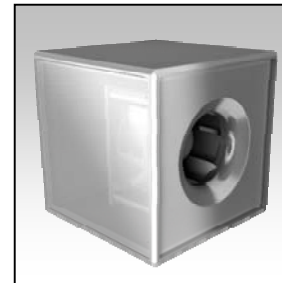

Unobox units

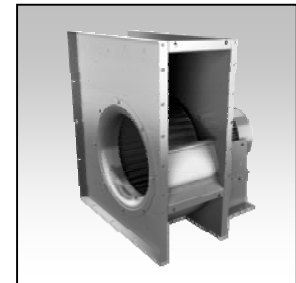

Centrifugal fans with IEC standard motor

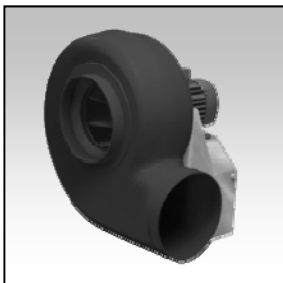

Plastic centrifugal fans

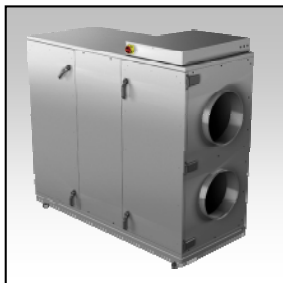

ERU's



Classroom Ventilation

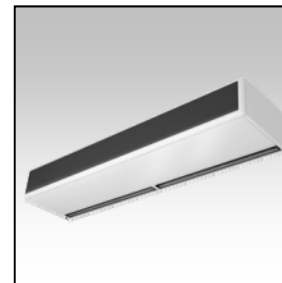

Air curtains



Speed-control-units

iv. What do we do ? - Product range standard - applications

Applications of standard products

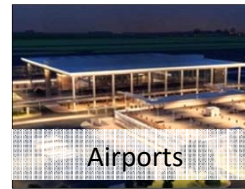

And many more ...

iv. What do we do ? - Product range standard - applications

Comfort & reliability...

Building example: schools

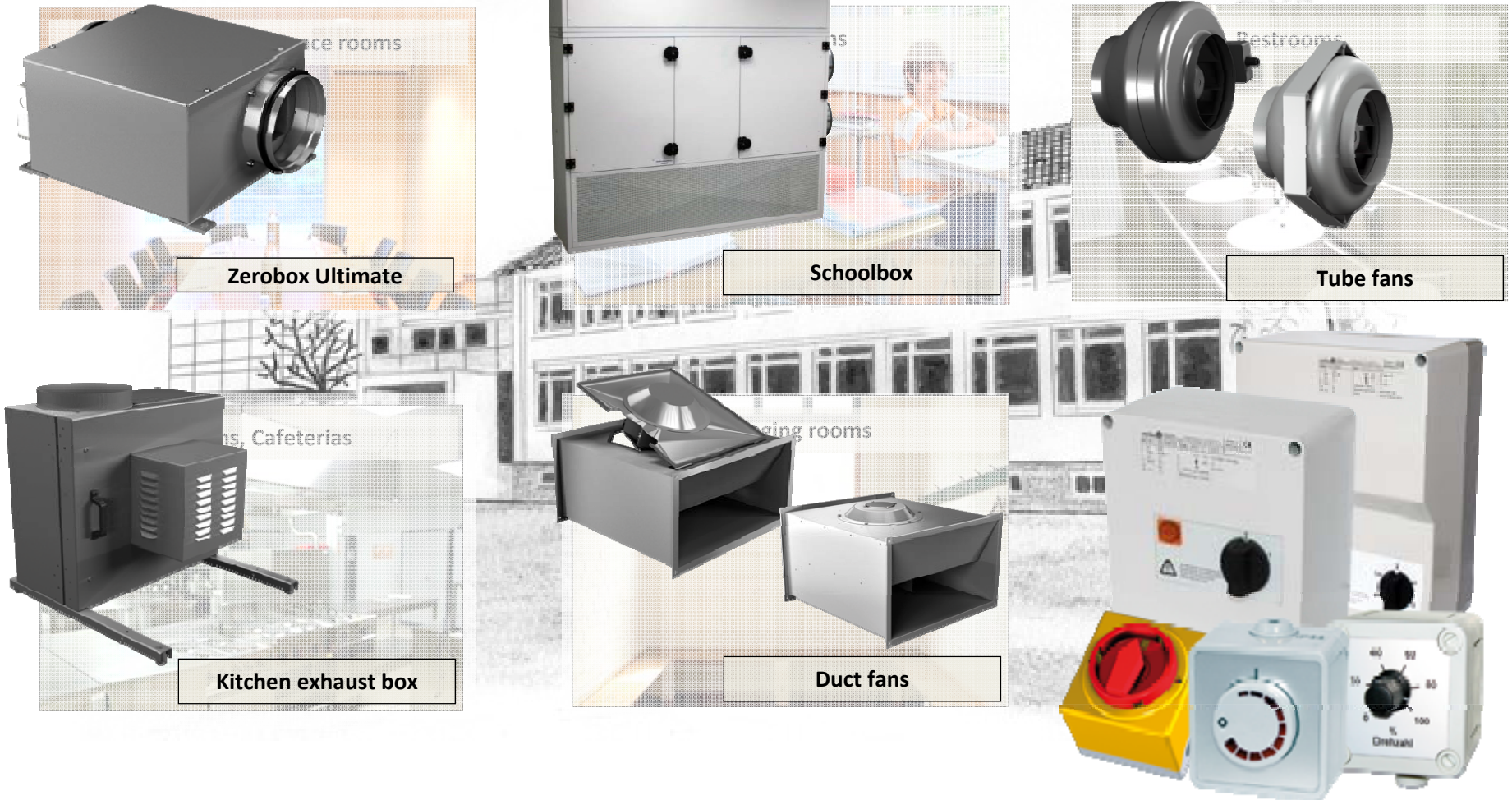

Zerobox Ultimate

Schoolbox

Tube fans

Kitchen exhaust box

Duct fans

iv. What do we do ? - Product range standard - applications

Comfort & reliability...

Building example: hotels



Suprabox

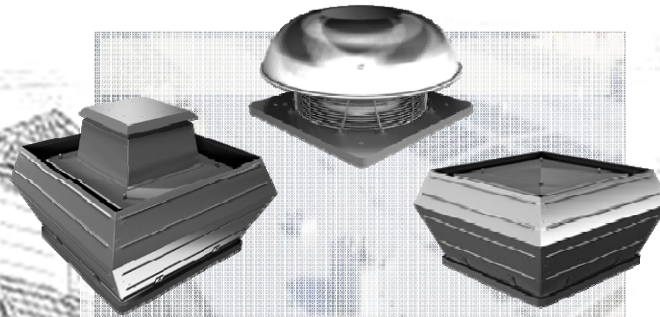

Roof fans



Air curtains



CompactAir



Kitchen exhaust box

iv. What do we do ? - Product range standard - applications

Powerfull & safe...

Building example: Industry



Axial fans / Air heaters



Smoke extract fans



Air curtains

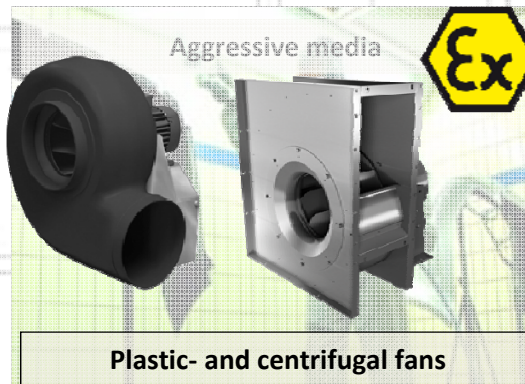

Plastic- and centrifugal fans

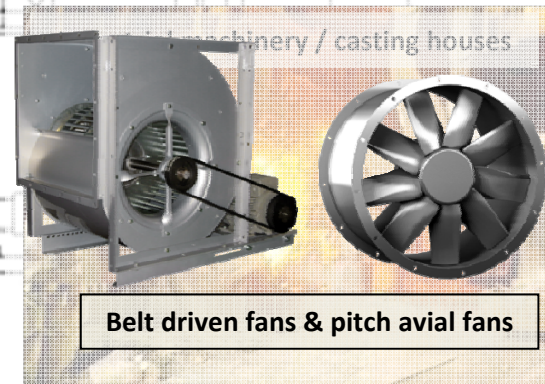

Belt driven fans & pitch axial fans

iv. What do we do ? - Product range OEM fans

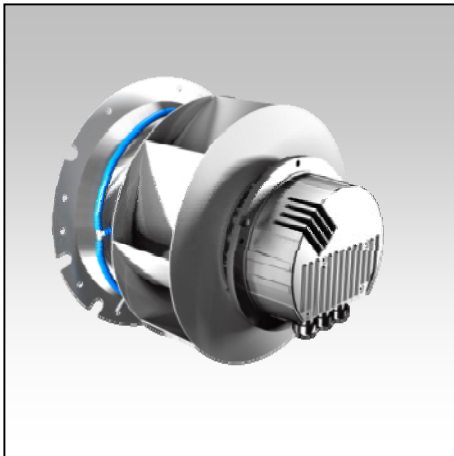

Backward curved motorized impellers (AC + EC)

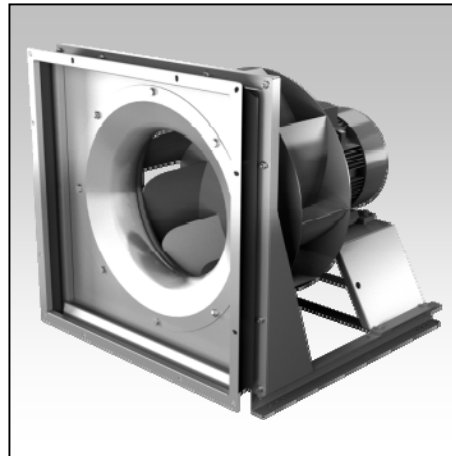

Free-running impellers as plug fan (IEC + EC)

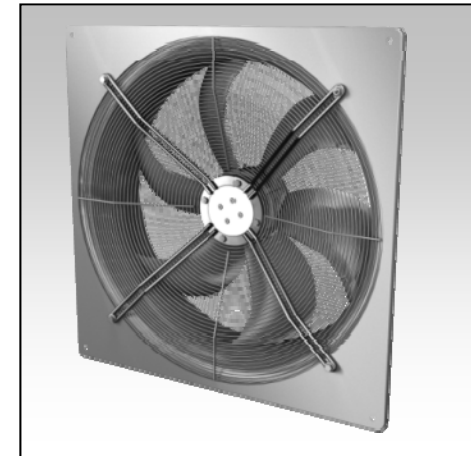

Sickle bladed axial-fans (AC + EC)

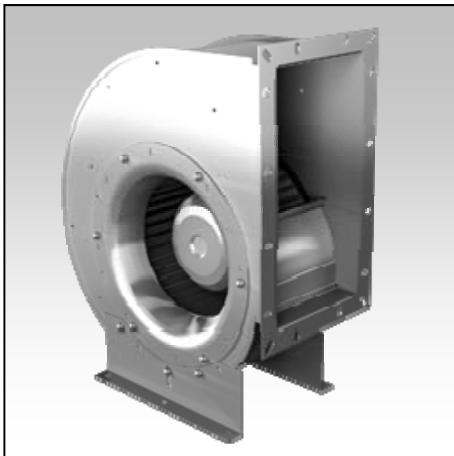

Single inlet centrifugal fans (forward- and backward inclined)

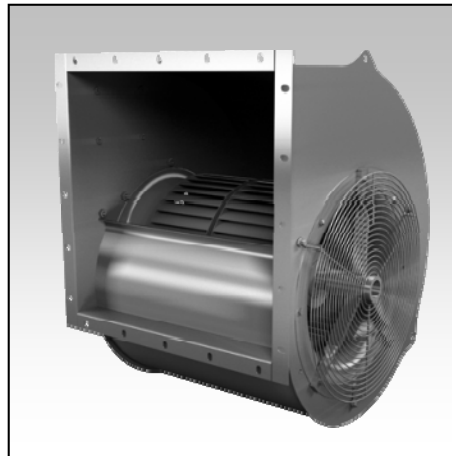

Double inlet centrifugal fans (forward- and backward inclined)

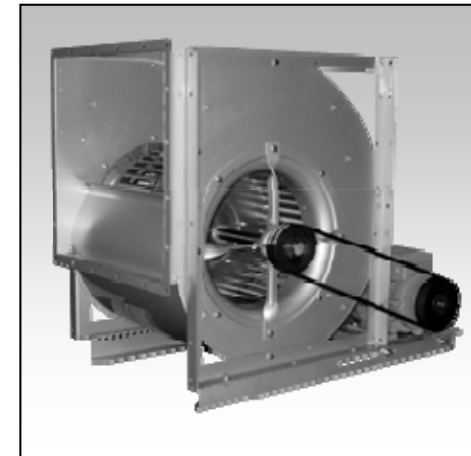

Single and Double inlet Belt driven fans (forward- and backward inclined)

iv. What do we do ? - Product range OEM fans - Railway

Railway technology:

- huge demand for high valued fans
- cooling of traction motors, transformers, electronic components
- air conditioning of passenger cabins / driver cabs
- successful on all continents since 1981
- shock stress, high thermal loads, voltage peaks
- Trend: backward curved impeller with external rotor motor
= core competence of the Rosenberg Ventilatoren GmbH



iv. What do we do ? - Product range OEM fans - Railway

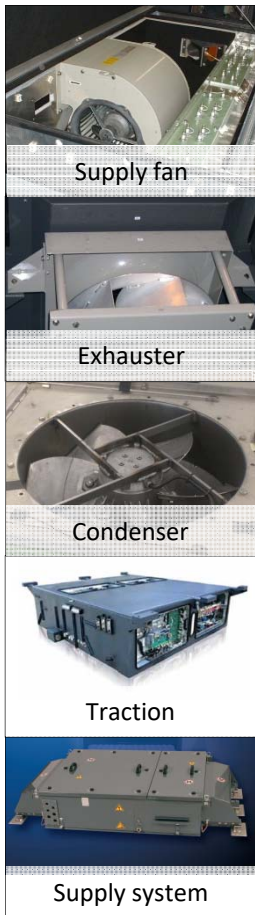

iv. What do we do ? - Product range OEM fans - Wind power

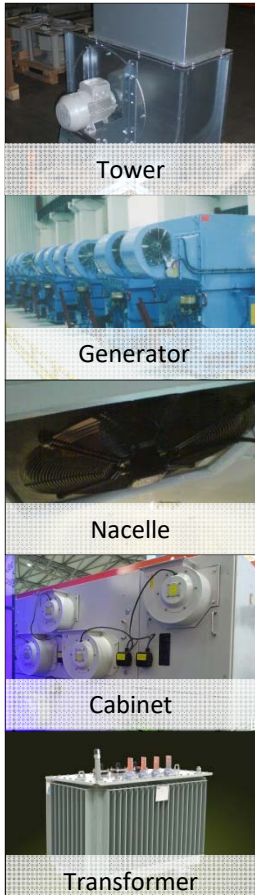

iv. What do we do ? - Product range OEM fans - Wind power

Wind Energy

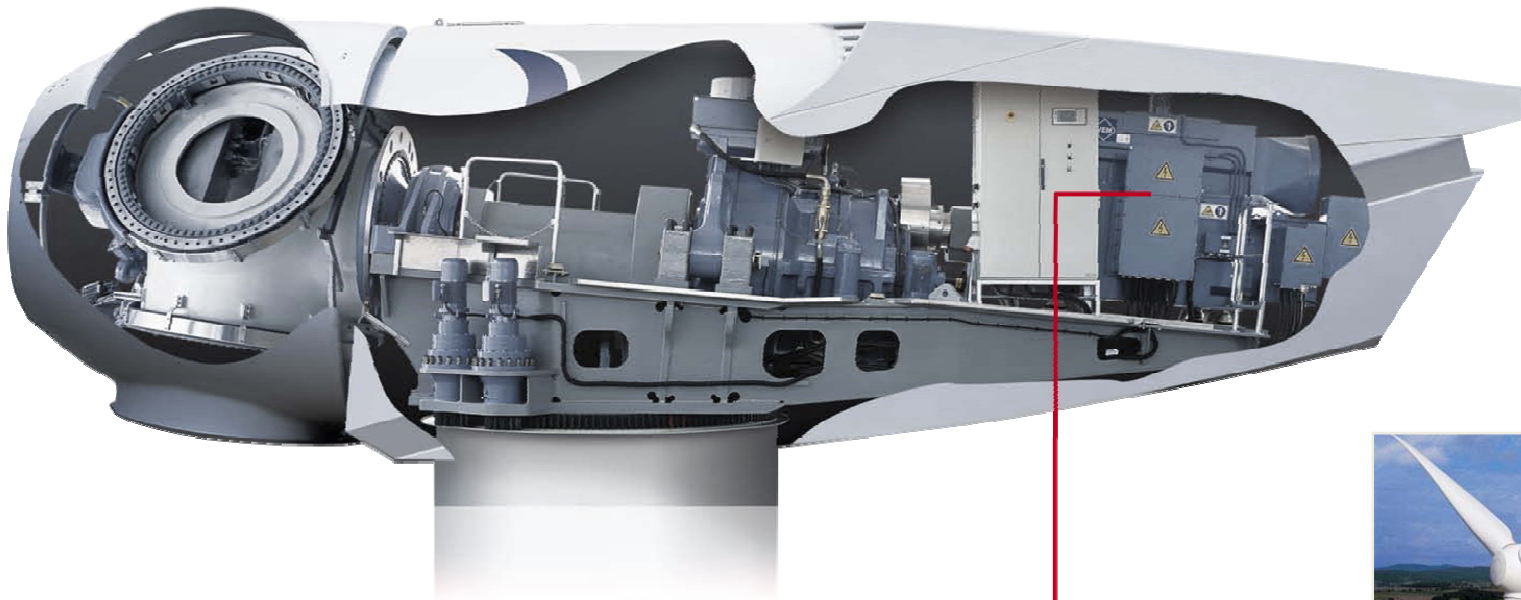

Energy production with wind turbines

Rosenberg fans in modified executions are used for cooling within wind turbines more and more frequently

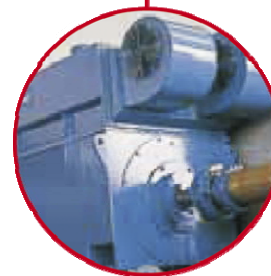

iv. What do we do ? - Product range OEM fans - HVAC

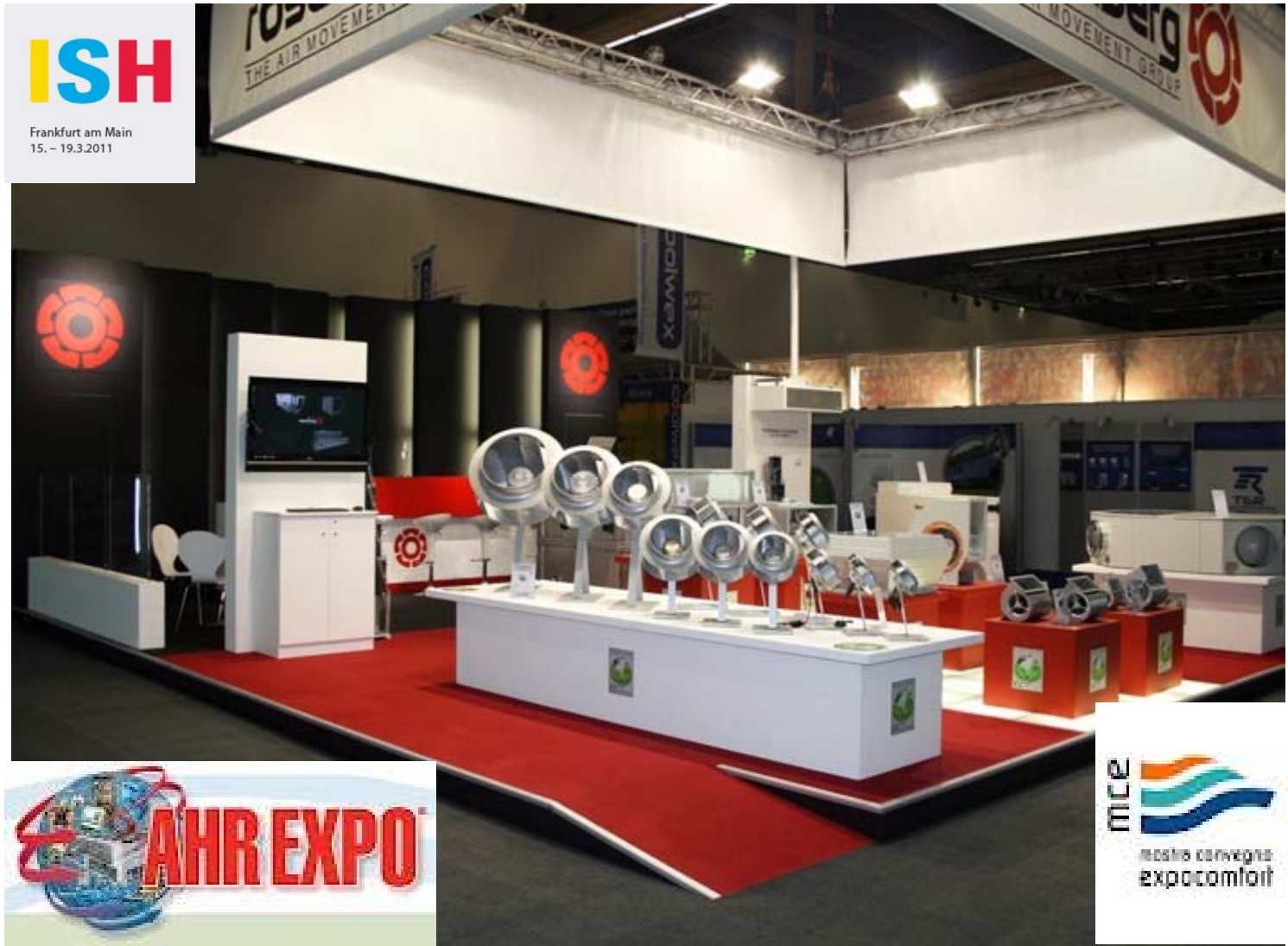

iv. What do we do ? - Product range OEM fans - Refrigeration



iv. What do we do ? - Product range OEM fans - Compressed air









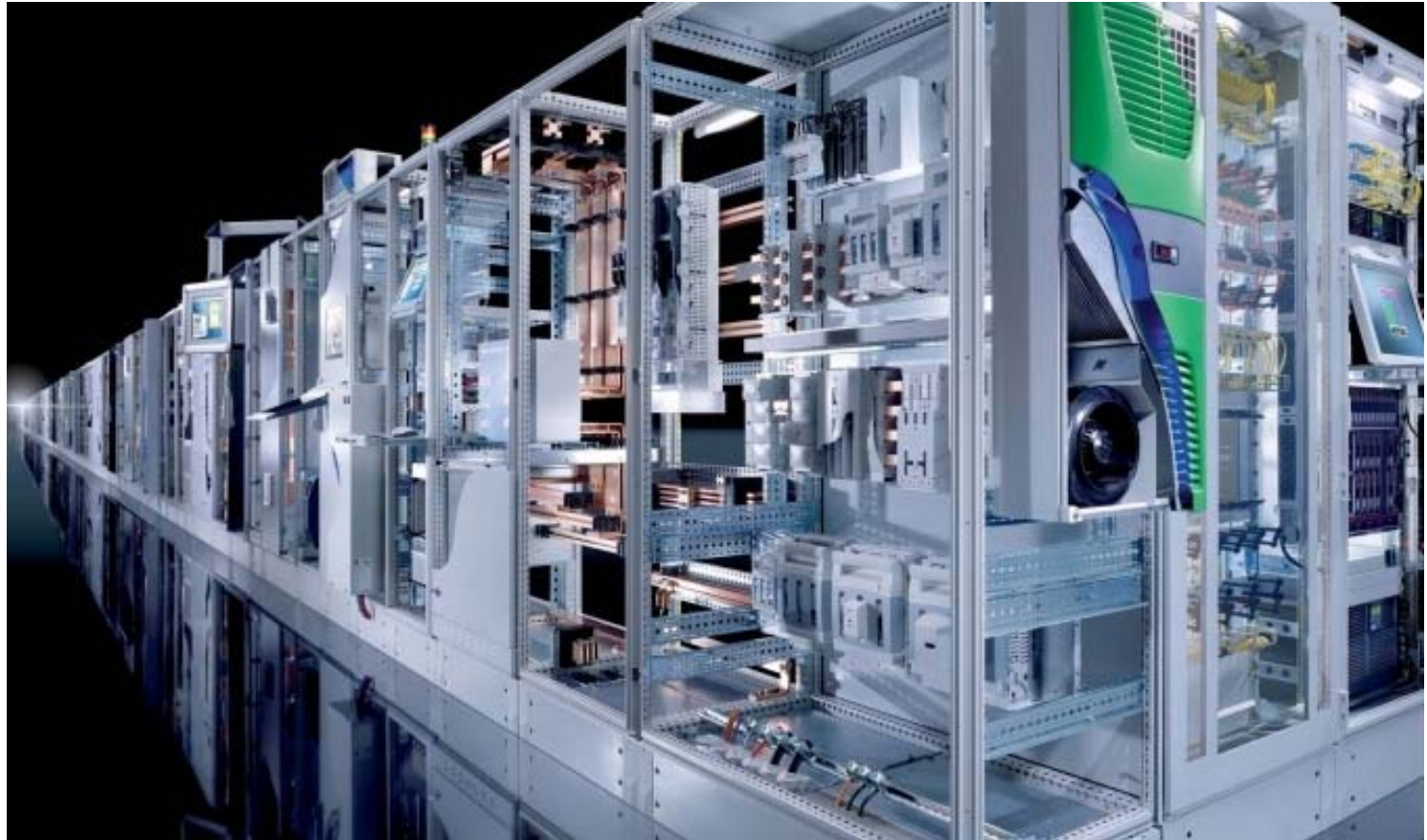





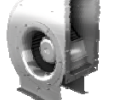

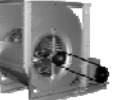



























iv. What do we do ? - Product range OEM fans - Filter & Cleanroom



iv. What do we do ? - Product range OEM fans - Electrical cabinets



iv. What do we do ? - Product range OEM fans - „Our“ applications

Application \ Fan-type						
HVAC						
Railway technology						
Wind power						
Refrigeration						
Compressed Air Treatment						
Filter- and Clean room-Technology						
Electrical Cabinets						
Electrical Machines						
Machine Construction Technology						

iv. What do we do ? - Product range AHU



AHU with 60 mm insulated panel

AHU with 40 mm insulated panel



iv. What do we do ? - Product range AHU

All ventilation processes feasible.

Huge variety of materials and coatings 5 product ranges (A20/F40/S40/S60/I60)

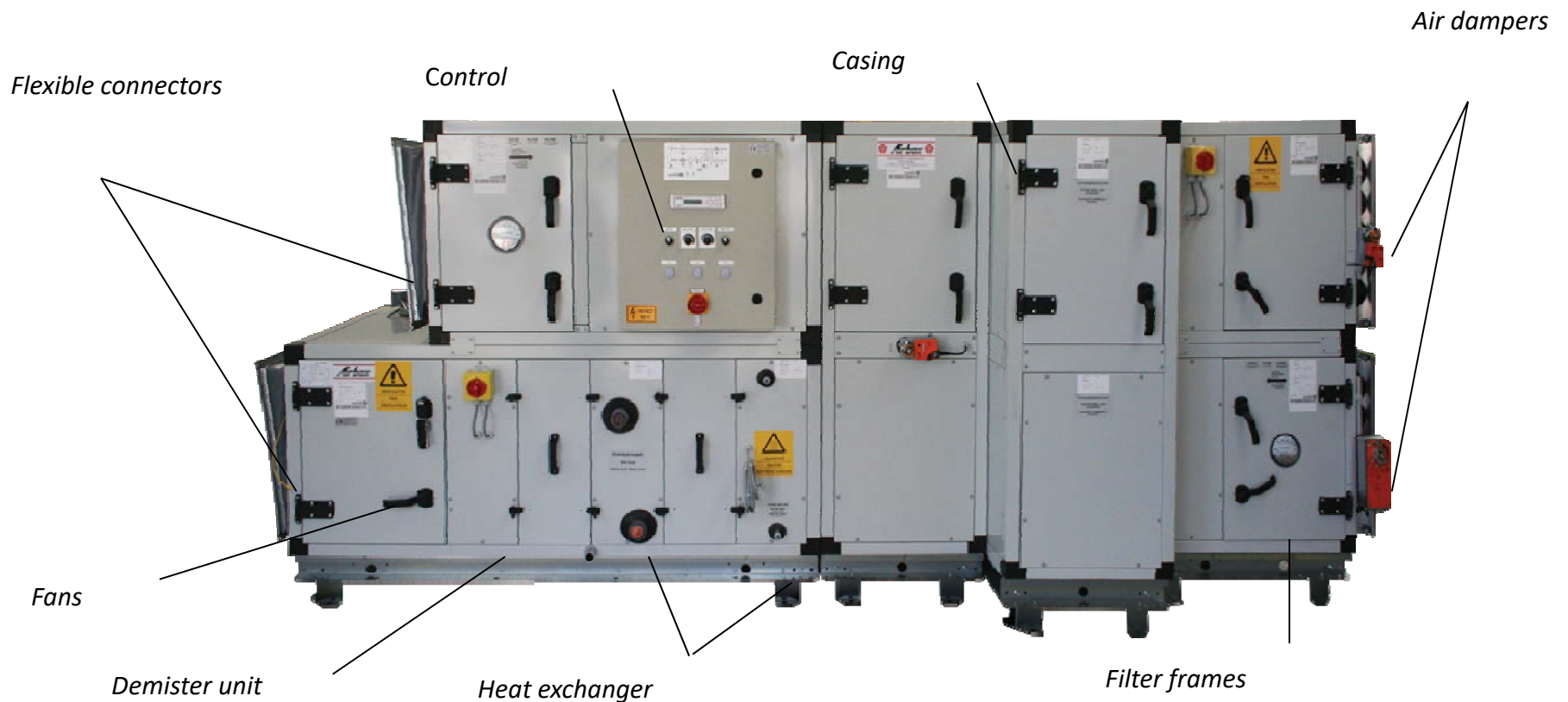

Rosenberg AHU's are suitable for almost every application

iv. What do we do ? - Product range AHU - Fresh air



- High flexibility
- Indoor and Outdoor units
- Central ventilation station
- Suspended ceiling installation
- Excellent thermal and acoustic characteristics
- Each ventilation concept is feasible

iv. What do we do ? - Product range AHU - Industrial applications



- High flexibility
- Huge variety of material
- - Precise and flexible control
- - Reliability
- Performance capability

iv. What do we do ? - Product range AHU - Hygienic design



Hospitals



Pharmacy



Food industry



Institutes, Labs



- Easy to clean
- Corrosion resistance
- High grade filters
- DIN EN 1946
- Absolute pristine air

iv. What do we do ? - Product range AHU - Ex-proof



- Non-combustible materials
- Correct material pairings
- Prevention of sparking
- Paramount safety
- Declaration of Conformity according ATEX-guideline

iv. What do we do ? - Product range AHU - Tailor-made

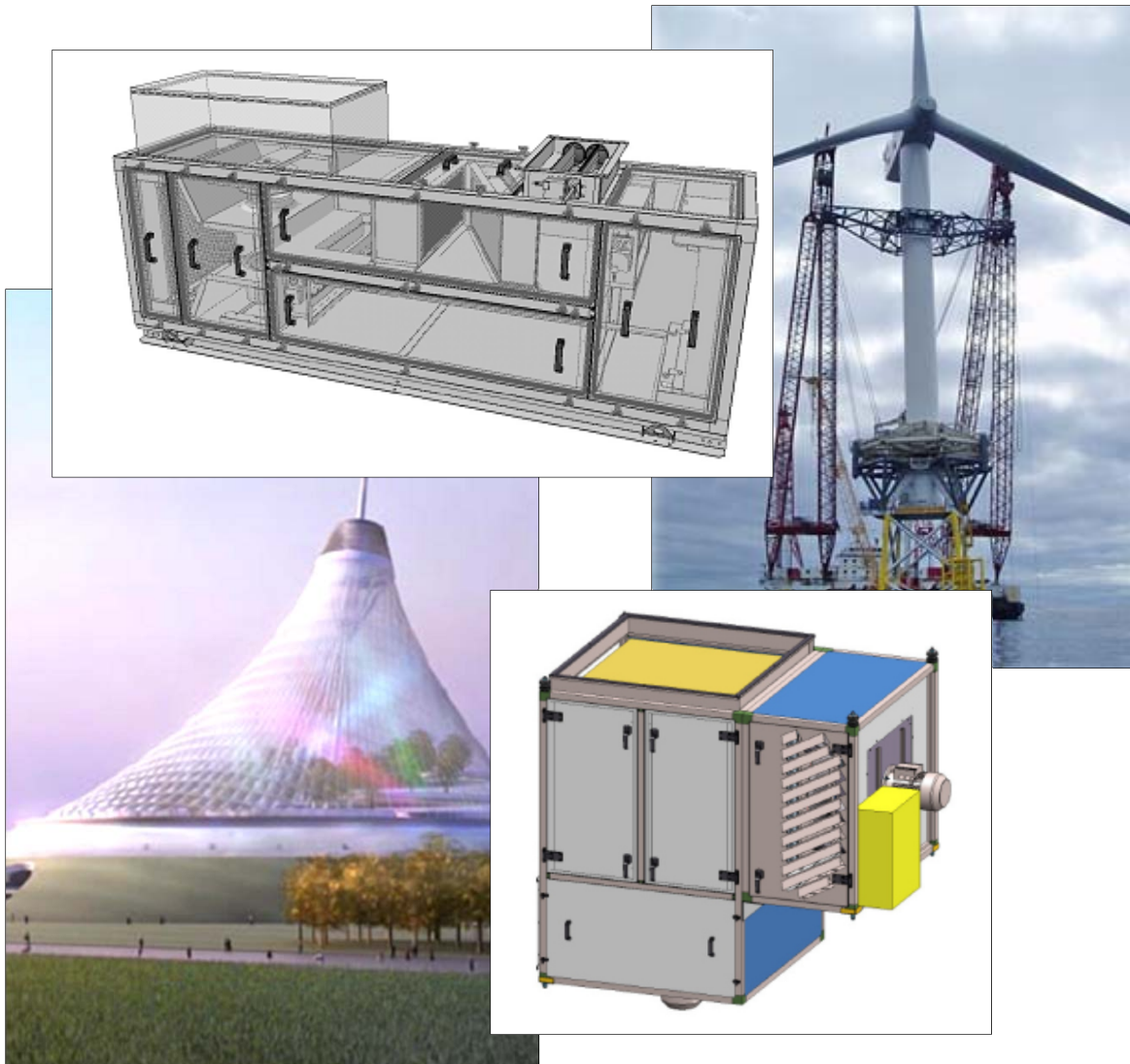

- Upmost flexibility
- Know-How
- 30 years of experience
- „Deep“ Production
- Customer orientation

Presentation Overview

i. Who are we ?

- Relevant data
- Rosenberg Ventilatoren GmbH
 - Headquarters
 - Glaubitz Production AHU
- Rosenberg worldwide

ii. What we stand for ?

- Philosophy

iii. Where do we come from ?

- History

iv. What do we do ?

- Product range Standard
- Product range OEM fans
- Product range Air handling units (AHU)

v. What we offer you ...

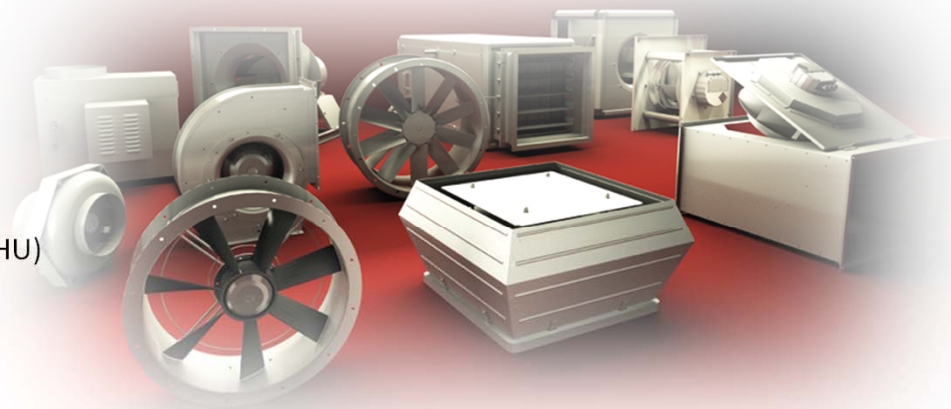
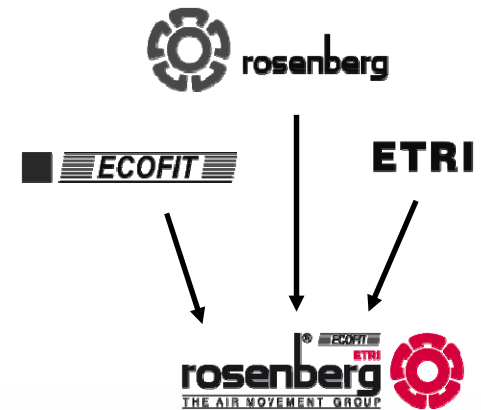

v. We offer you ...



Manufacturer with a wide range

„Complete solutions of one source“

- Production of motors, fans, Plug&Play Units, AHU's and controls
- High flexibility for special solutions
- Independent from suppliers because of a depth of production

Know-How for many years

„own research&development“

- Huge amount of ErP-Ready fans
- Continuous improvement by state-of-the-art test-labs
- Market leader in railway technology – the most challenging OEM segment



Thank you for your attention

